



Light is Vision.

intralux® dc-1100

Cold Light Source

Part Number 16615/16605



Instruction Manual

Volpi USA
5 Commerce Way, Auburn, NY 13021
Tel. 315-255-1737, Fax. 315-255-1202
volpi@volpiusa.com, www.volpiusa.com

Fiber Optics | Optics | Opto-Electronics | Engineering

P/N 16325 Revised 4/2011
© 2007 VOLPI USA
All Rights Reserved

Unit and Its Components

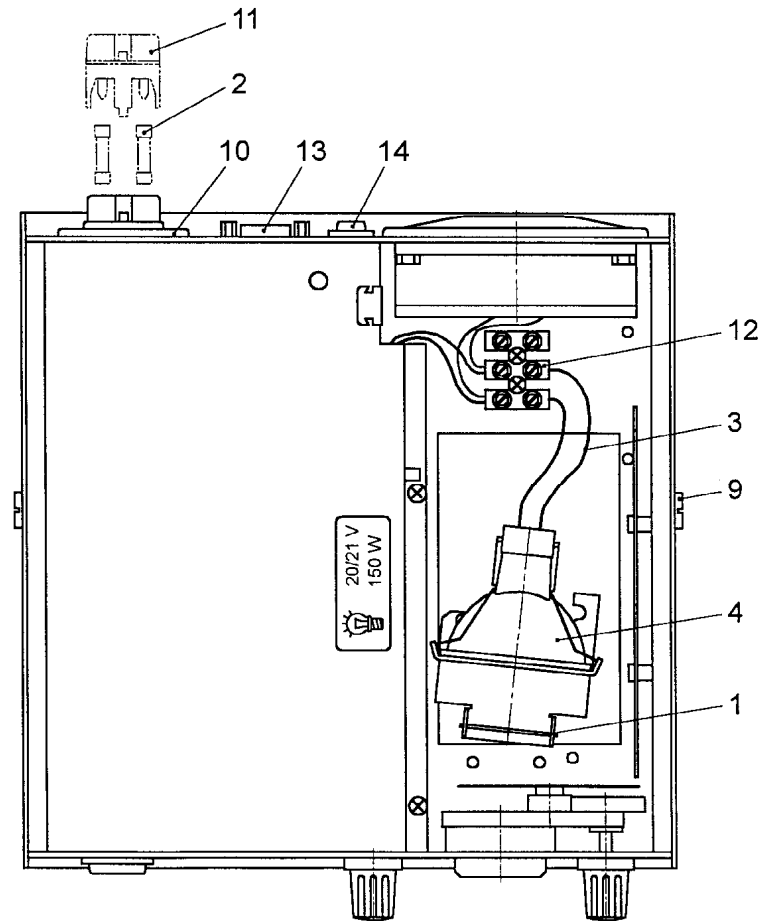
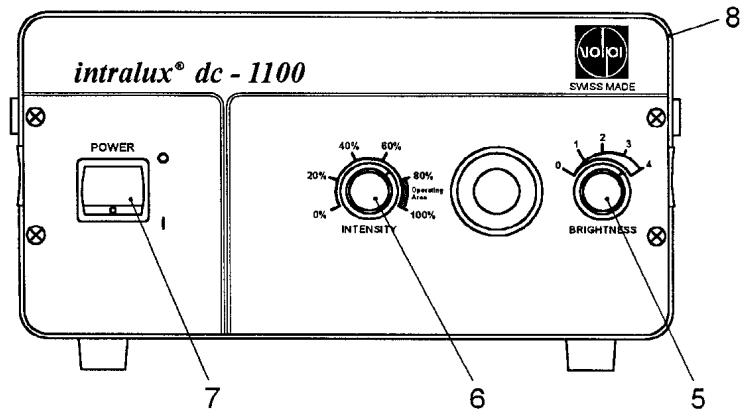



Light is Vision.

Spare Parts

	P/N 16615 <u>120V</u>	P/N 16605 <u>230V</u>
1. Heat protection filter	91611.006	91611.006
2. Fuse	90045.130	90045.118
3. Lamp socket.	25750.045	25750.045
4. Halogen lamp EKE 21V/150W	13695	13695
Halogen lamp DDL 20V/150W	23500.014	23500.014
Power cord	90032.114	2093.01

Legend

1. Brightness control knob (crescent shaped diaphragm)
2. Intensity control knob
3. Power switch
4. Cover
5. Cover screw
6. Power entry unit
7. Fuse Holder
8. Cable terminal
9. Serial interface RS-232 (optional)
10. Throw-over switch (optional)

Ambient Conditions

For Operating:

Ambient temperature	0°C to 40°C
Relative humidity (RH) (Non condensing)	5% to 95%
Over voltage category	Class II
Pollution degree	2

For Storage:

Ambient temperature	-25°C to +70°C
Relative humidity (RH)	5% to 95%

Electrical Data

	P/N 16615 <u>120V</u>	P/N 16605 <u>230V</u>
Line Voltage	120VAC/60Hz	230VAC/60Hz
Maximum power consumption	230W	230W
Fuse	3.15AT	2.5AT

A. Starting up

1. First check, whether the factory-set voltage corresponds with the local voltage.
2. Loosen cover screws (9) on both sides and remove cover (8).
3. Connect halogen lamp (4) into socket (3) and push it down into the lamp holder to a positive- stop. Do not touch the bulb or the reflecting surface of the lamp!
4. Replace cover (8) and refasten cover screws (9).
5. Plug the power cord into the power entry unit (10) and connect to the power outlet.
6. Switch throw-over switch (14) at the rear housing in position, "Local".
7. Switch power switch (7) on the front of the instrument to position **1**.

Caution:

- Installation and maintenance only by qualified person.
- Use only the delivered Power Cable. The maximum allowed length of the RS 232 Serial Interface Cable is 3m
- The banana plugs on the rear side of the unit are for manufacturer's use only.
- The safety of the light source can only be guaranteed if used according to the operation instructions.
- Clean the light source with a moist cloth. Unplug the light source first !
- Lamp life depends to a large extent on its operating temperature. To achieve best results, please observe that the air can flow freely (Air inlet at bottom of housing, air outlet on the rear of housing)!

B. Operation

1. Plug the power cord into the power entry unit (10) and connect to the power outlet.
2. Switch throw-over switch (14) at the rear housing in position "Local".
3. Switch the power switch (7) on the front of the instrument to position **1**.
4. Adjust intensity with the intensity control knob (6). (This regulation of intensity changes the color temperature of the lamp and affects its life.)
5. When the intensity setting has been selected, the light supply can be adjusted continuously by means of brightness control (5).



Light is Vision.

C. Lamp Replacement

Caution:

- Lamp should be cooled off before touching!

1. Set the power switch (7) on the front of the instrument to position **0** and disconnect the power cord from the instrument and from the voltage outlet.
2. Remove cover according to A.2.
3. Remove the defective lamp (4) together with the lamp socket (3) from the lamp holder and remove it from the lamp socket (3). Replace the lamp (4) with a new one (EKE or DDL-type).
4. Further steps as per A.3 -A.7.

D. Fuse Replacement

1. Set the power switch (7) on the front of the instrument to position **0** and disconnect the power cord from the instrument and from the voltage outlet.
2. Pull out fuse holder (11) on the rear of the housing.
3. Replace the defective fuses (2) with spare fuses. (Replace only of same type as per manufacturer's label!).
4. Close the fuse holder (11).
5. Further steps as per A.5 – A.7.

E. Lamp Socket Replacement

Caution:

- If the lamp socket (3) shows signs of burning and wear between the lamp pin contacts it must be replaced.
- Lamp should be cooled off before touching!

1. Set the power switch (7) on the front of the instrument to position **0** and disconnect the power cord from the instrument and from the voltage outlet.
2. Remove cover according to A.2.
3. Remove the halogen lamp (4) together with the lamp socket (3) from the lamp holder and remove it from the lamp socket (3). Do not touch the bulb or the reflecting surface of the lamp!
4. Separate the old or damaged lamp socket (3) from the cable terminal (12) and replace it with a new one.
5. Further steps as per A.3 -A.7.

F. Serial Interface RS-232 (Optional)

1. Cable:

The connection of the computer and the Intralux dc-1100 light source needs two wires: Signal and Ground.

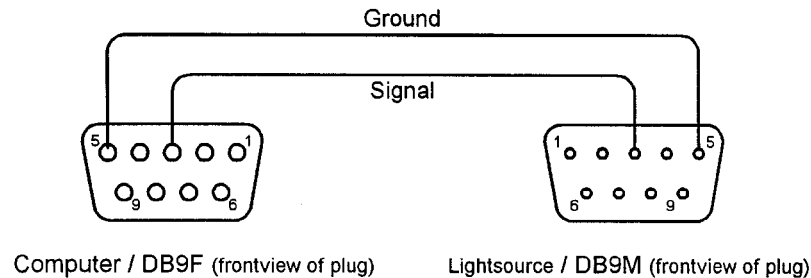

2. Setup of the serial interface:

The serial interface needs following setup:

Baud: 9600	Data bits: 7	Stop bit: 7	Parity: even
------------	--------------	-------------	--------------

3. Communication:

The interface contains a 10-bit DAC. That means that the range of brightness can be adjusted from 0 (dark) to 1023 (max. intensity). The DAC features a serial input. To program the desired brightness 12 bits must be transmitted. First, 10 bits data (MSB first), second, 2 dummy bits. For each bit, a whole RS-232 data package has to be transmitted. To send a 0, the value of this package is 0 too; to send a 1 the value is 255 (0xff).

Due to the internal structure of the interface the value of the brightness has to be "inverted", i.e. subtracted from 1023.

Example: Program the brightness value to 555

1. Step: invert the value
 $1023-555=468$
2. Step: convert 468 in a 10-digit binary number
 $468 \text{ (dec.)} = 0'111'010'100 \text{ (bin.)}$
3. Step: transmit 10 bits
send (0), send (255), send (255), send (255), send (0), send (255)
send (0), send (255), send (0), send (0)
4. Step: transmit 2 dummy bits
send (0), send (0).